

STEPPING MOTORS

SP33-1001

FEATURES

- Provided with connector terminal for easy connection
- RoHS compliant

APPLICATIONS

- Game machines
- Others

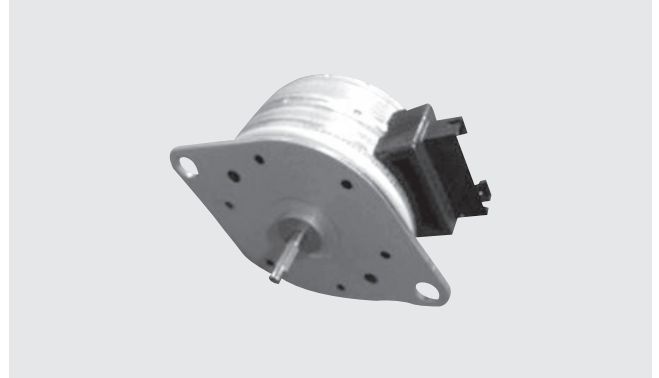

PART NUMBER DESIGNATION

SP 33 - 1001

Series name

Dash number

OUTLINE DIMENSIONS

Unless otherwise specified tolerance: ± 0.5 (Unit: mm)

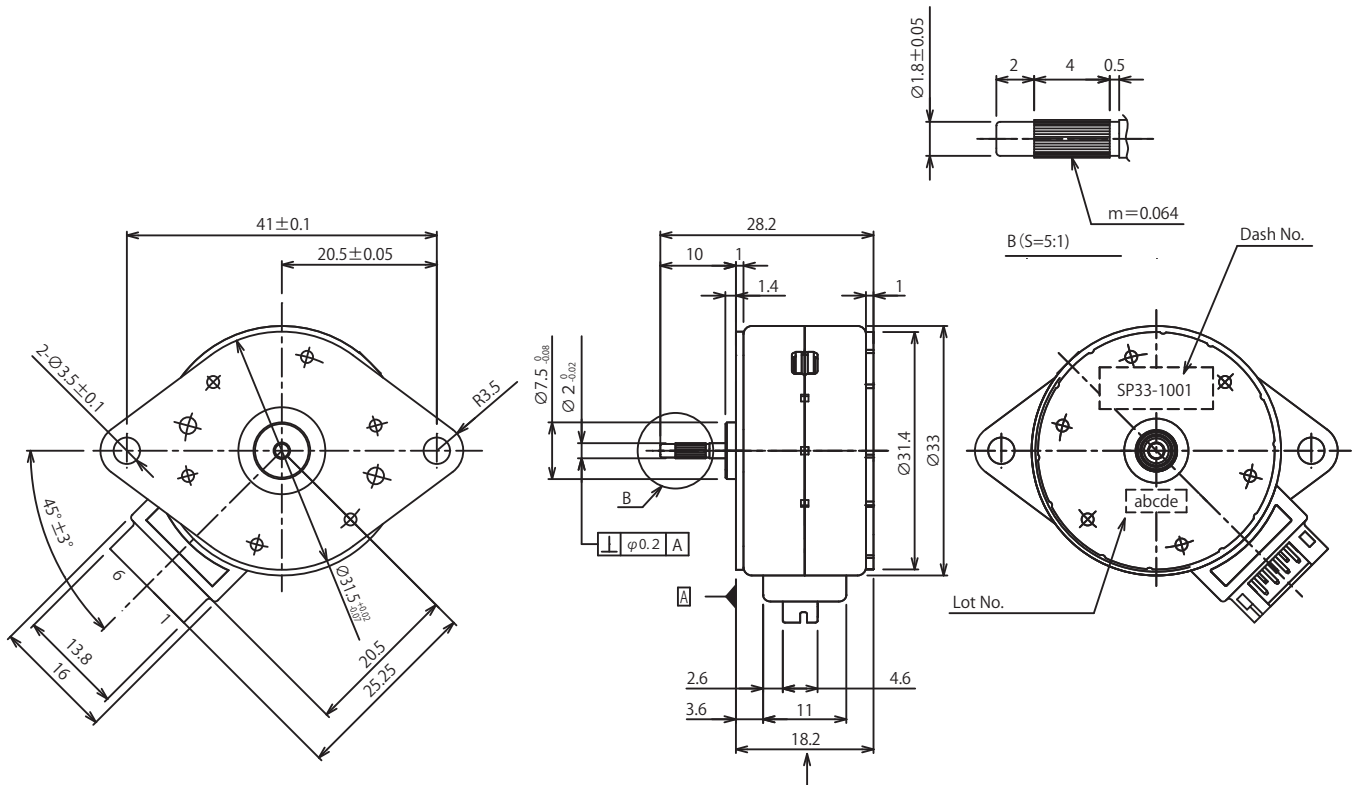

Lot production is required. Please consult us for ordering.

SP33-1001

STEPPING MOTORS

STANDARD SPECIFICATIONS

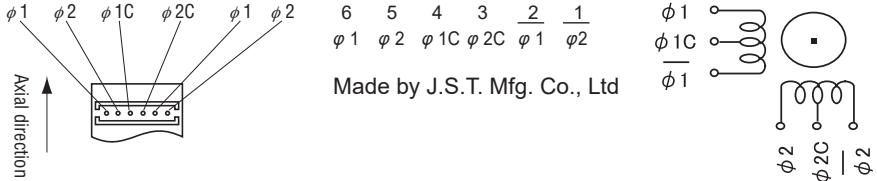
Item	SP33-1001
Number of phases	4 phases unipolar(Substitutable as two bipolars due to open common terminal pins.)
Number of poles	12
Step angle	15° (2 phases-EX.)
Steps	24 (2 phases-EX.)
Winding resistance	21 Ω (±10%)
Voltage	DC12V
Power	Average power consumption 7W Max.
Current/Phases	Refer to PERFORMANCE CURVES
Pull-in torque	
Pull-out torque	
Pull-in pulse rate	
Maximum continuous response frequency	
Temperature rise(Δ t)	Refer to TEMPERATURE CHARACTERISTICS
Insulation resistance	30 MΩ minimum at 500 VDC (the winding and a case)
Dielectric strength	500 Vrms(AC50Hz,1min)
Operating temperature range	0 ~ 50 °C
Allowable thrust load	9.8 N
Standard connector terminal	<p>Male connector 06CR-6H-P、06KR-6H-P or PHR-6</p>  <p>Made by J.S.T. Mfg. Co., Ltd</p>

SP33-1001

STEPPING MOTORS

■ PERFORMANCE CURVES (REFERENCE VALUE)

12V-2phases-EX.

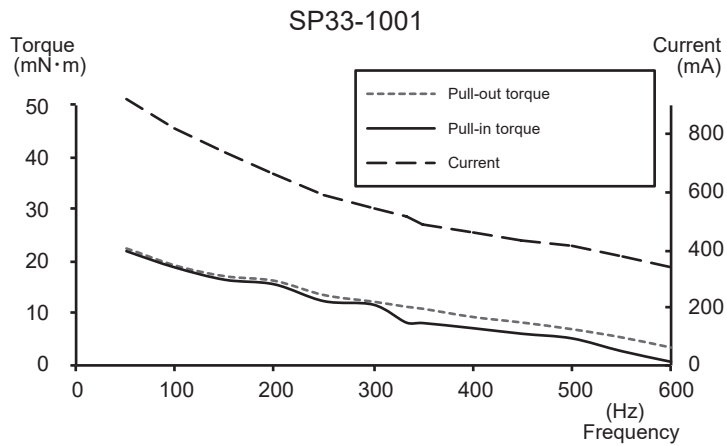

※ These performance curves show actual value, not guaranteed value.

■ TEMPERATURE CHARACTERISTICS (REFERENCE VALUE)

12V-2phases-EX.

