

# GLOSSARY

## POTENTIOMETERS

---

---

---

---

---

---

---

---

### ■ RESOLUTION

The output ratio for wirewound potentiometers shows the smallest value of change.

#### ● Theoretical degradation

The formula for theoretical degradation in wirewound potentiometers is shown below.

$$\text{Theoretical degradation} = \frac{1}{N} \times 100 (\%)$$

N: The total number of windings within the effective electrical angle.

#### ● Angle degradation

The angle degradation shows the ratio (percentage) of the angle  $\alpha$  needed to reduce the output voltage one step to the total electrical angle.

$$\text{Angle degradation} = \frac{\alpha}{\ell} \times 100 (\%)$$

$\alpha$  : Theoretical degradation angle  
 $\ell$  : Effective electrical angle

#### ● Voltage degradation

This shows the ratio (percentage) of the smallest output voltage to the voltage between the terminals (applied voltage).

$$\text{Voltage degradation} = \frac{e}{E} \times 100 (\%)$$

E: Voltage between the terminals

e: Smallest degradation voltage

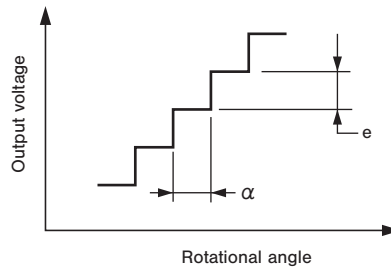

### ■ END RESISTANCE AND ABSOLUTE MINIMUM RESISTANCE

This is the resistance caused by the relation of the effective electrical angle and the mechanical rotation angle.

#### ● Effective electrical angle < Mechanical angle

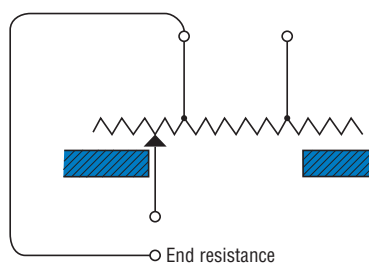

#### ● Effective electrical angle > Mechanical angle

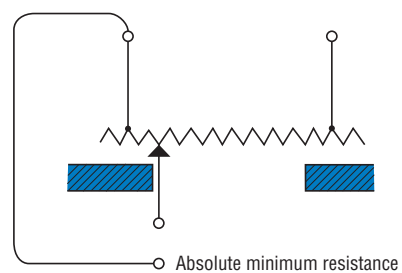

### ■ LINEARITY

Linearity is the deviation of the output voltage from the output voltage reference line from the rotation angle. There are four ways to choose the reference line. These include independent linearity, absolute linearity, terminal linearity, and zero reference linearity.

#### ● Independent linearity

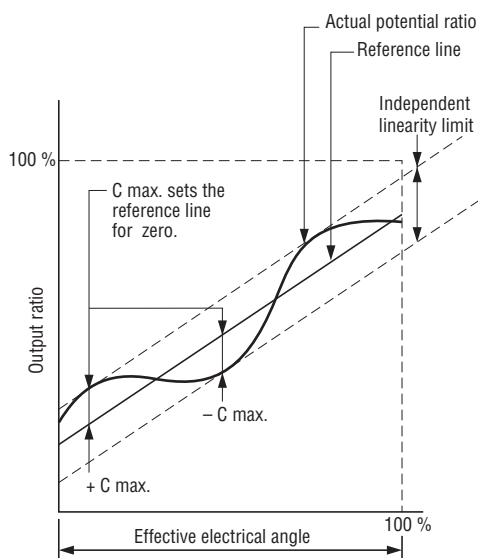

#### ● Absolute linearity

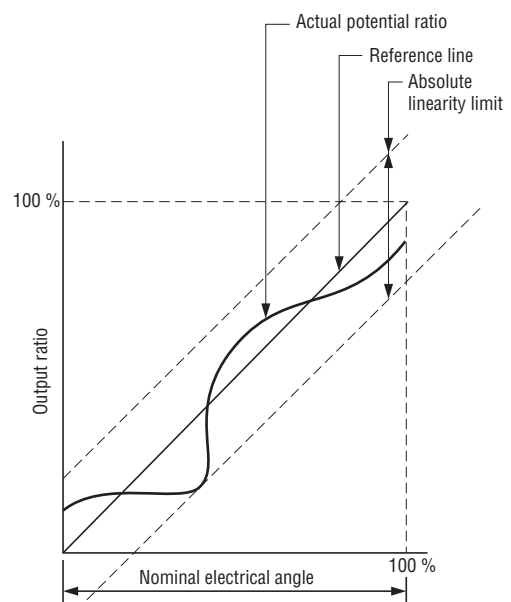

# GLOSSARY

## POTENTIOMETERS

### LOOKING AT ACTUAL DATA FROM INDEPENDENT LINEARITY

Unless otherwise specified, the linearity of our potentiometers is based on the independent linearity. The measurement of the linearity is made by comparing the actual output from the potentiometer and the computer generated theoretical reference output. The independent linearity is defined as shown below.

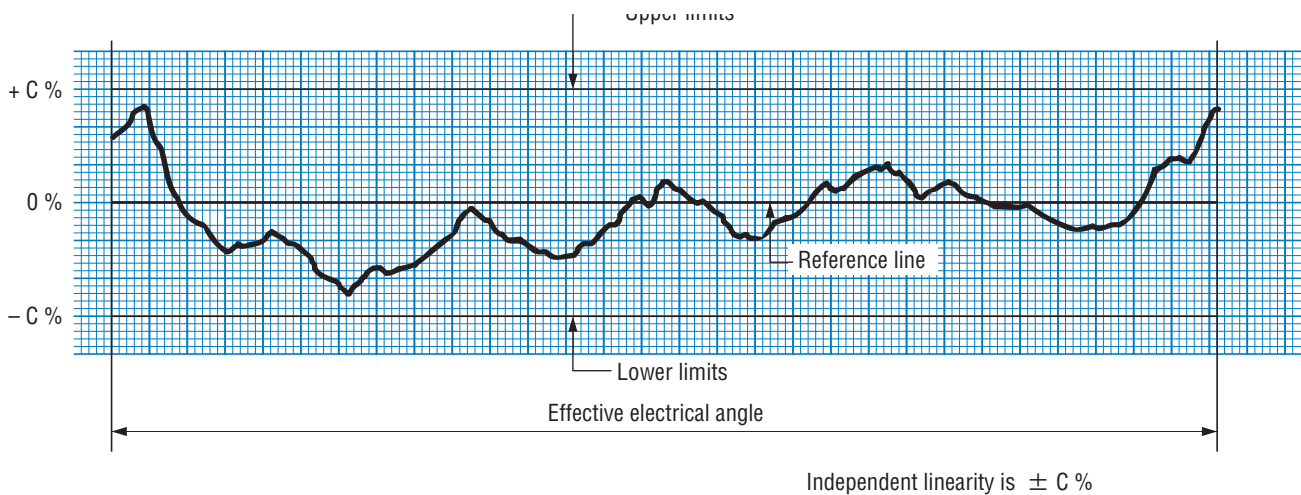

### OUTPUT SMOOTHNESS

The output smoothness represents output stability of conductive plastic potentiometers when the shaft is rotated and is expressed by the ratio (percentage) of the output voltage variation to the input voltage. The measuring circuit is as shown below.

$$\text{Output smoothness} = \frac{\text{Output voltage variation (e)}}{\text{Input voltage (E)}} \times 100 (\%)$$

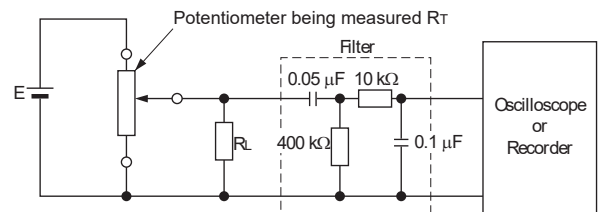
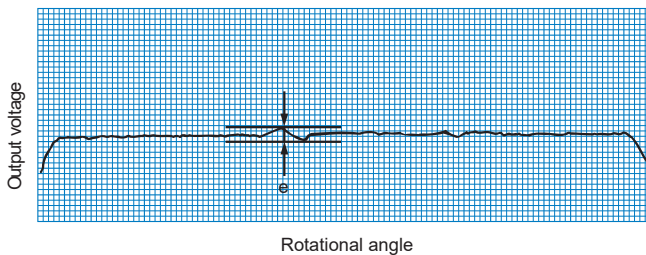

Filter: MIL-R-39023  
 Resistance load  $R_L : R_L = R_T \neq 100$   
 Rotational speed :  $4 \text{ min}^{-1}$

### ■ EFFECTIVE ELECTRICAL ANGLE AND MECHANICAL ANGLE

A: This is the effective electrical angle and shows the actual change in output voltage as the volume of shaft movement.

B: This is the effective electrical angle and shows the actual change in output voltage as the volume of shaft movement.

C: This is the dead angle and shows the portion where the wiper and the resistor are completely electrically disconnected.

D: This is the mechanical rotation angle and shows the movement of the shaft. When there is no stopper, this angle is 360°.

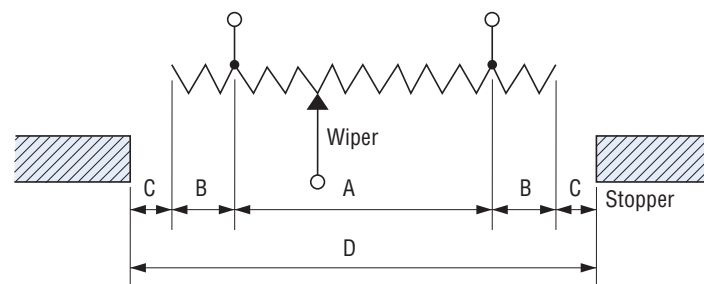

### ■ ROTATIONAL NOISE

This is equivalent noise resistance that occurs when the potentiometer's shaft is rotated and is also called peak noise. This test method is specified in MIL-R-12934F, and the equivalent noise resistance here is calculated as follows:

$$\text{Rotational noise} = \frac{E_p}{0.001} (\Omega)$$

$E_p$ : The peak noise voltage (V) displayed on the oscilloscope.

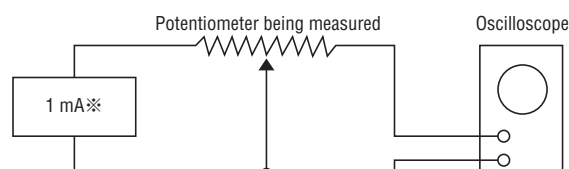

Shaft rotation speed: 4 min<sup>-1</sup>  
Oscilloscope frequency band width: DC ~ 50 kHz over

※ DC1 mA constant current power supply

# GLOSSARY

## POTENTIOMETERS

### LOADING ERROR

The output accuracy of a potentiometer is adversely affected by the input impedance of the next stage (or the load of the potentiometer). This is called "loading error".

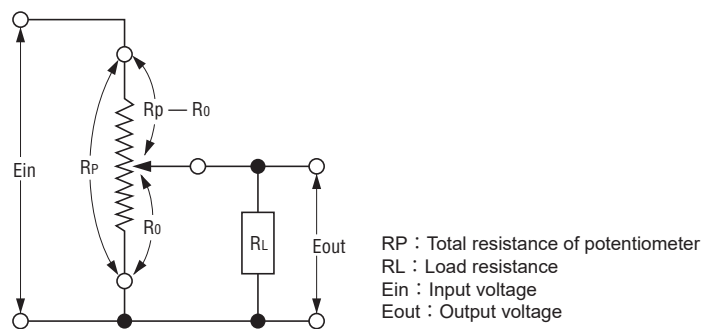

In the above diagram, if the load impedance is infinitely large, the output voltage ratio of the potentiometer will be proportional to the resistance change ratio.

$$\frac{E_{out}}{E_{in}} = \frac{R_o}{R_p}$$

However, if the load impedance is limited, the output voltage ratio is shown as follows.

$$\frac{E_{out}}{E_{in}} = \frac{R_o}{R_p + (R_p - R_o) \frac{R_o}{R_L}}$$

Loading error is shown by the following formula:

$$\delta = \frac{\left(1 - \frac{R_o}{R_p}\right) \left(\frac{R_o}{R_p}\right)^2}{\frac{R_L}{R_p} + \left(1 - \frac{R_o}{R_p}\right) \frac{R_o}{R_p}} \times 100 (\%)$$

### PROTECTION GRADE

- Protection grade applies to the environment of potentiometer use
- The Protection grade aims at water protection. For the oil or various types of liquid, please be reminded that the degree of protection is different.

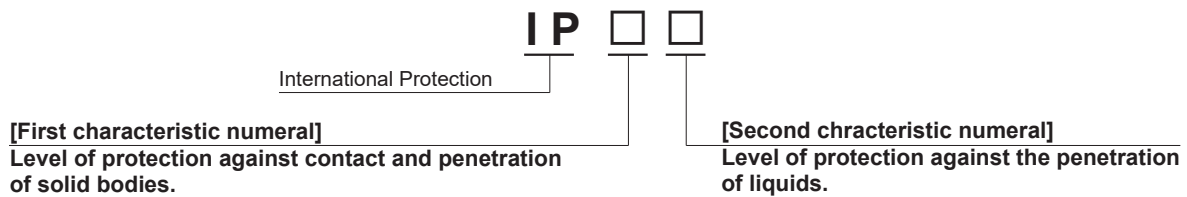

Grade	Degree of protection	
0		No protection
1		Protected against solid foreign objects such as hands of $\phi$ 50 mm and greater.
2		Protected against solid foreign objects such as finger of $\phi$ 12.5 mm and greater.
3		Protected against solid foreign objects such as tools or wires of ( $\phi$ or thickness of) 2.5mm and greater.
4		Protected against solid foreign objects such as tools or wires of ( $\phi$ or thickness of) 2.5mm and greater.
5		Protected against such dust as damages the equipment operation.
6		Dust-tight

**[Related standards]**  
IEC (The International Electrotechnical Commission) standard IEC 60529  
Degrees of protection provided by enclosures

JIS(Japanese Industrial Standards ) standards JIC-C-0920  
Test to prove protection against ingress of water and degree of protection

Grade	Category	Degree of protection	
0			No protection
1	Drip-proof I type		Protected against vertically falling water drops.
2	Drip-proof II type		Protected against vertically falling water drops when enclosure is tilted up to 15°.
3	Rain-proof type		Protected against rainfall when enclosure is tilted up to 60°.
4	Splash-proof type		Protected against splashing water.
5	Water-jets-proof type		Protected against water jets.
6	Waterproof type		Protected against powerful water jets.
7	Watertight type		Protected against the effects of temporary immersion in water.
8	Underwater type		Protected against the effects of continuous immersion in water.